

**Shelf Trucks**

**Capacity Range**

**500 – 1,000 lbs.**

★ **SH5002** Capacity to 1,000 lbs.



- Two tray-type steel shelves turned up 1½": 14 ga. on 36" and 48" lengths; 12 ga. with center rail on 60" length.
- Clearance between shelves 18¼"; height to lip of top shelf with 8" wheels 32¼"; to handle 38"; higher with Pneumatic-tired wheels.
- Two swivel and two rigid casters bolted to formed 12 ga. longitudinal bolsters. See chart for wheel choices.
- Roller bearings standard in all wheels, except ball bearings in *Ace-Tuf®* wheels.
- Capacity 1,000 lbs. with 8" wheels, 750 lbs. with 5" wheels.

★ = two-day **PRONTO®** shipment.

**SH5002 Selection Table**

Shelf Size Inches	SELECTION SUFFIX				Approx. Weight Lbs.
	8 x 2.50 <i>Ace-Tuf®</i>	8 x 2.80-4 Pneumatic	5" x 2" <i>Versa-Tech®</i>	8" x 2" <i>Versa-Tech®</i>	
24 x 36★	-8AT2436★	-8PR2436★	-5TE2436★	-8TE2436★	115
24 x 48	-8AT2448	-8PR2448	-5TE2448	-8TE2448	135
30 x 48★	-8AT3048★	-8PR3048★	-5TE3048★	-8TE3048★	185
30 x 60	-8AT3060	-8PR3060	-5TE3060	-8TE3060	230

TO ORDER, SPECIFY MODEL NUMBER AND SUFFIX

★ **SH5003** Capacity 1,000 lbs. Instrument Cart shown with optional bumpers.



- Two 14 ga. steel shelves: bottom shelf turned up 1½".
- Clearance between shelves 18"; height to top shelf 32¼"; to handle 37"; higher with Pneumatic-tired wheels.
- Anti-static ¼" thick non-skid rubber mat on both shelves.
- Two swivel and two rigid casters bolted to formed 12 ga. longitudinal bolsters. See chart for caster/wheel choices.
- Rubber bumpers available.

★ = two-day **PRONTO®** shipment.

**SH5003 Selection Table**

Shelf Size Inches	SELECTION SUFFIX			Approx. Weight Lbs.
	8 x 2.50 <i>Ace-Tuf®</i>	8 x 2.50 Pneumatic	8 x 2.50 <i>Super-Flex™</i>	
24 x 36★	-AT2436★	-PR2436★	-SU2436★	120
24 x 48	-AT2448	-PR2448	-SU2448	150
30 x 48★	-AT3048★	-PR3048★	-SU3048★	170
30 x 60	-AT3060	-PR3060	-SU3060	250

TO ORDER, SPECIFY MODEL NUMBER AND SUFFIX

★ **SH5016** Capacity 500 lbs.



- Size 20" wide x 36" long x 38" high overall (push handle adds 3" to length).
- Two 16 ga. steel shelves welded to steel angle uprights.
- Clearance between shelves 23½"; all edges turned up 1½".
- Stem-type casters welded on: two swivel and two rigid with 5" x 1½" *Poly-Tech®* ball bearing wheels.
- Weight 75 lbs.

★ **Shippable PRONTO®.**

★ **SH5017** Capacity 600 lbs. Plate-type casters bolted-on.



- Size 17" wide x 34" long x 35" high overall (push handle adds 3" to length).
- Three shelves of 16 ga. sheet steel with 12¾" clearance above middle shelf, 10" clearance below. Top shelves tray-type 2" deep; bottom shelf edges turned down.
- Casters bolted to 14 ga. formed longitudinal bolsters; two swivel and two rigid casters with 5" x 1¼" *Versa-Tech®* wheels with ball bearings.
- Weight 85 lbs.

★ **Shippable PRONTO®.**

**Shelf Trucks**  
Capacity Range  
600 – 6,000 lbs.



**Work Height Platform Truck**  
PWB1108 Capacity 2,000 lbs.

- Deck of 1" select hardwood set flush in steel frame.
- Frame of 2" x 1" x 3/16" steel angle.
- 8" x 2" wheels in two swivel and two rigid casters (except Pneumatic tires, size 8" x 2.80/2.50-4).
- Casters bolted to 3/16" steel angle cross bolsters.
- Removable pipe handle sockets with set screws.
- Platform height 31" standard; special heights upon request.

**TO ORDER, SPECIFY MODEL NUMBER AND SUFFIX**

★ = two-day  
**PRONTO®** shipment.

**PWB1108 Selection Table**

Platform Size Inches	SELECTION SUFFIX				Approx. Weight Lbs.
	Moldon Rubber	Plastex	Pneumatic Tires *	Polyplast	
24 x 48★	-R2448★	-P2448★	-PR2448★	-AY2448★	160
30 x 48★	-R3048★	-P3048★	-PR3048★	-AY3048★	170
30 x 60★	-R3060★	-P3060★	-PR3060★	-AY3060★	185

\* Capacity limited to 1,200 lbs. with 8" Pneumatic tires.

**Table Trucks**  
SH5030 Capacity 1,500 lbs.



- Size 30" wide x 40" long x 31" high overall. Special sizes also available—advise details.
- Top of 14 ga. sheet steel reinforced with 1 1/2" x 1 1/2" x 3/16" angle center support.
- Bottom frame, corner uprights and caster bolsters all 1 1/2" x 1 1/2" x 3/16" angle.
- Casters two swivel and two rigid with 6" x 2" Versa-Tech® wheels, or 6" x 1 1/2" Metal or Plastex wheels.
- Roller bearings in all wheels.

**SH5030-M** with Metal wheels.

**SH5030-P** with Plastex wheels.

**SH5030-TE** with Versa-Tech® wheels.

## Bar Handling Trucks

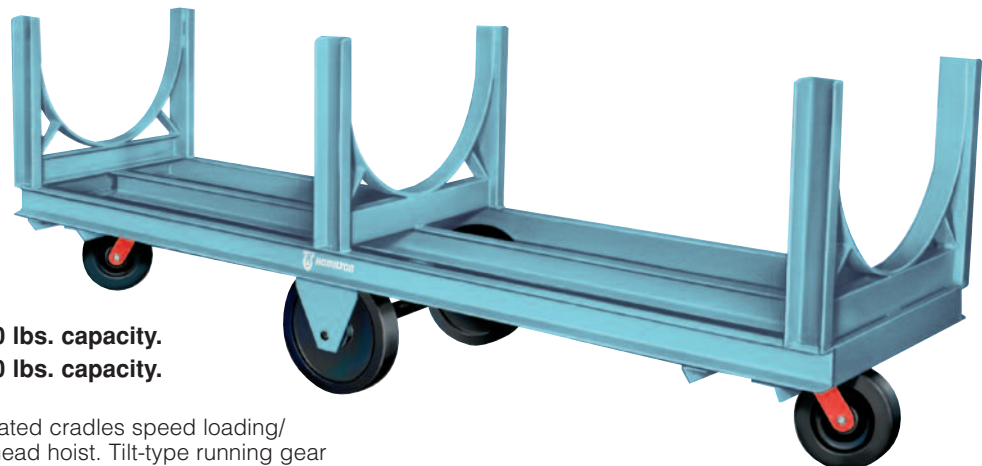

**BH485** 5 ft. long—3,000 lbs. capacity.  
**BH488** 8 ft. long—6,000 lbs. capacity.

**Bar Handling Trucks** Elevated cradles speed loading/unloading by forklift or overhead hoist. Tilt-type running gear permits turning in its own length. Standard with one swivel caster at each end, but available with two swivel casters at each end when uneven floors exist. Frame and uprights constructed of steel channel. Cradles made of 3/8" flat steel 15" deep.

**BH485** is 26" wide x 60" long x 32" high overall with two 12" x 2 1/2" load wheels on a 1" dia. axle and two forged steel swivel casters with 8" x 2" roller bearing wheels. Weight 250 lbs.

**BH488** is 26" wide x 96" long x 33 1/2" high overall with two 12" x 3" load wheels on a 1 1/4" dia. axle and two forged steel swivel casters with 8" x 2 1/2" roller bearing wheels. Weight 460 lbs.

To order, specify BH485-D or BH488-D with *Duralast®* polyurethane wheels; 485-M or 488-M with Metal wheels; 485-P or 488-P with Plastex wheels.